

ZOLLER Product Portfolio Measuring
Technology 4.0 for your Grinding Shop

ZOLLER
expect great measures

ZOLLER Solutions Measuring Technology



ZOLLER Solutions for your Grinding Process

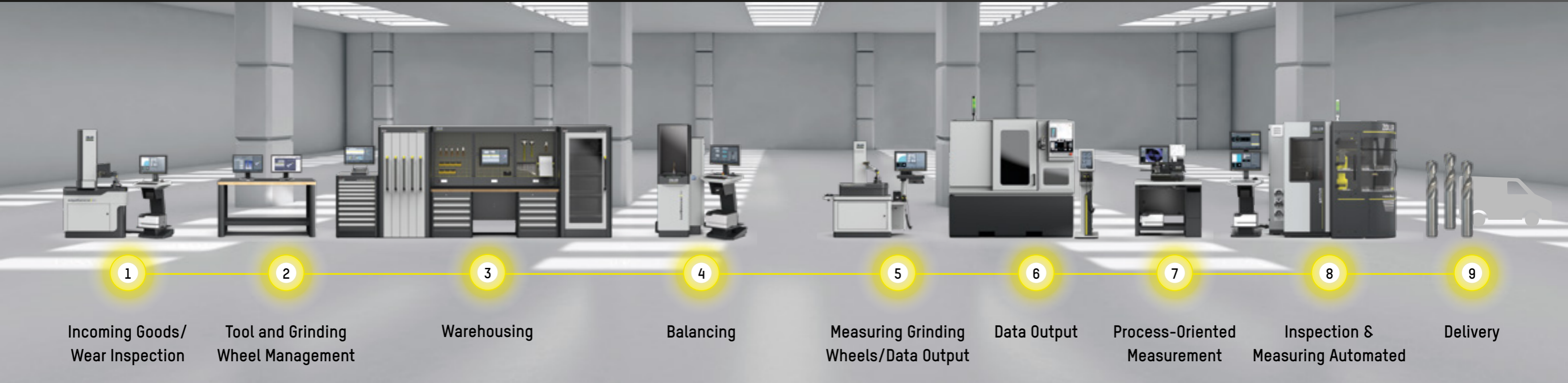

Content Overview

Discover our
ZOLLER Solutions

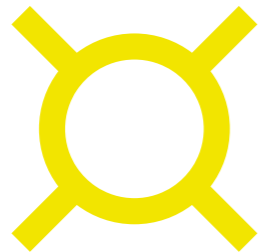

04 TOOL MANAGEMENT/SOFTWARE Tool and Grinding Wheel Management	20 INSPECTION & MEASURING »threadCheck cc«
06 WEAR INSPECTION »edgeControl 600« & »edgeControl«	22 INSPECTION & MEASURING »titan«
08 TOOL MANAGEMENT/HARDWARE »toolOrganizer«	24 INSPECTION & MEASURING »hobCheck«
10 TOOL MANAGEMENT/HARDWARE »keeper«	26 INSPECTION & MEASURING »pomBasicCompact«
12 TOOL BALANCING TECHNOLOGY »toolBalancer«	28 INSPECTION & MEASURING »pomBasic« & »pomBasicMicro«
14 INSPECTION & MEASURING »smileCheck«	30 INSPECTION & MEASURING »µFocus«
16 INSPECTION & MEASURING »smartCheck«	32 AUTOMATION »roboSet 2«
18 INSPECTION & MEASURING »genius«	34 SOLUTIONS ZOLLER around the world

TMS Tool Management Solutions Software

2

In smart manufacturing, data plays an essential role. The central z.One database in conjunction with the browser-based webTMS software forms the innovative first step towards an efficient tool management system for your tools and your grinding wheels.

ZOLLER offers you a comprehensive range of software options from a single source: with webTMS you give the starting signal for your digitization. With BRONZE, SILVER and GOLD, a further range of software packages are available for your grinding process – with a modular design that can be expanded as you like.

solutions.zoller.info/en/toolmanagement



Tool and grinding wheel management

For maximum process reliability

Networked via the z.One central database



Exactly resharpened – ZOLLER »edgeControl«

1

With the ZOLLER »edgeControl 600« & »edgeControl«, you can perform efficient resharpening – with intuitive operation and precise measurement results. The incoming goods inspection provides not only actual geometry data but also measurement data on tool wear. ZOLLER's central z.One database manages all data for the tool management, the basis of the networked grinding shop of the future.



»edgeControl 600«



»edgeControl«

Benefits for your wear inspection

- Fully automatic measuring technology
- Fast detection of tool breakouts along the cutting edge
- Automatic analysis of the 3D model



Technical Data	»edgeControl 600«	»edgeControl«
Maximum tool length Z	600 mm	600 mm
Maximum tool diameter D	460 mm	100 mm
Maximum snap gauge diameter d	100 mm	100 mm
Weight	~ 430 kg	~ 1400 kg

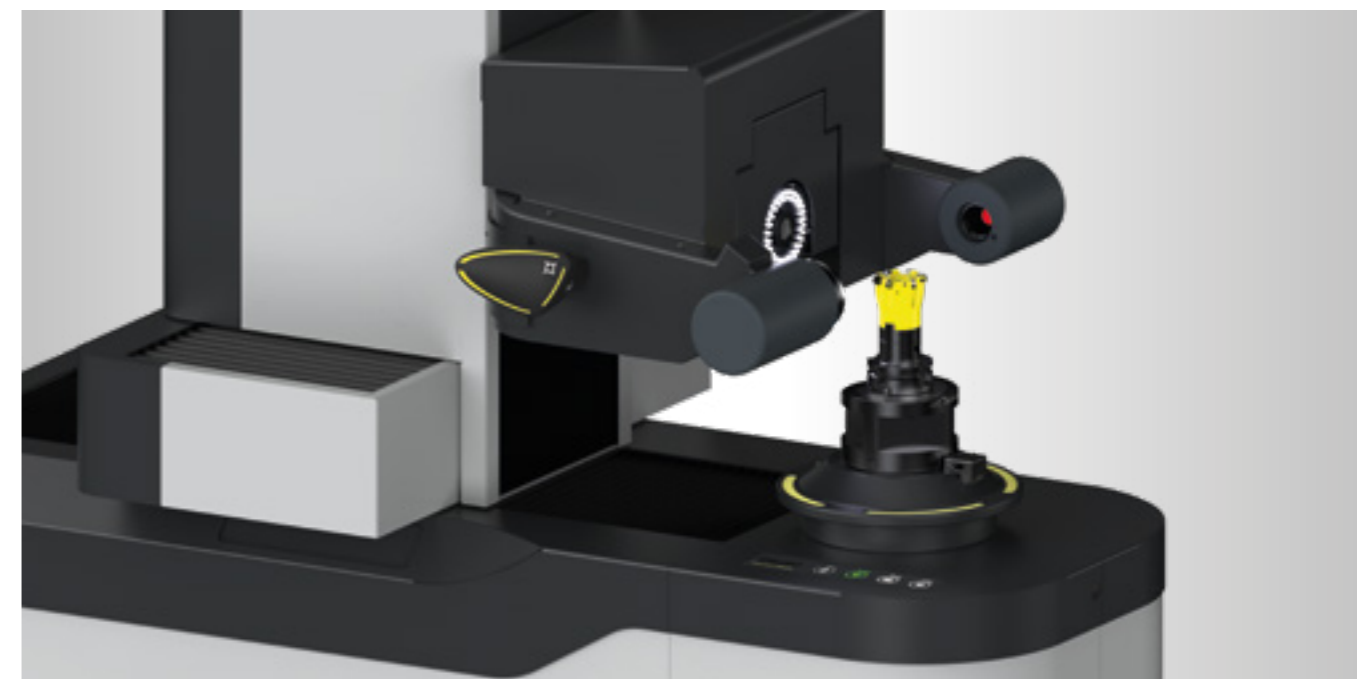

High-precision spindle »ace« with power-operated tool clamping

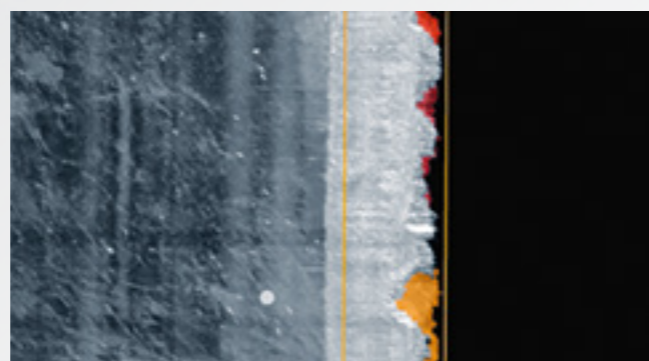

Wear evaluation at the radial relief angle



Software for precise grinding

»pilot 4.0« detects wear on cutting edges. Your tools are ground to achieve optimal results and a longer life cycle. This increases quality and resource efficiency.

Intelligently Stored – ZOLLER »toolOrganizer«

3

The ZOLLER »toolOrganizer« is the intelligent and variable tool cabinet for cutting tools, grinding wheels and small parts. With this organizational wonder connected to TMS Tool Management Solutions, you will always know where items are located and the quantities you have available. You can reorder them on time and decide exactly how many items are able to be taken out.



»toolOrganizer 900«

Benefits for your tool and grinding wheel management

- Maximum overview
- Full control and transparency
- Individually configurable



Technical Data	»toolOrganizer 600«	»toolOrganizer 900«	»toolOrganizer 1225«
Configurable useable height	600 mm	900 mm	1225 mm
Cabinet size (H x W x D)	875 x 800 x 790 mm	1175 x 800 x 790 mm	1500 x 800 x 790 mm
Payload per drawer	max. 80 kg optional max. 160 kg	max. 80 kg optional max. 160 kg	max. 80 kg optional max. 160 kg
Drawer height	75/100/125/150/ 175/200/250/300 mm	75/100/125/150/ 175/200/250/300 mm	75/100/125/150/ 175/200/250/300 mm
Drawer divisions (compartments)	4/8/12/16/24/48	4/8/12/16/24/48	4/8/12/16/24/48



Find out more about the ZOLLER »toolOrganizer« on: solutions.zoller.info/en/smart-cabinets



Intelligent LEDs are used for visual orientation



Individual drawers, customized according to your needs



Simple storage management with »quickPick«

Control the removal process easily with the smart software modules of the TMS Tool Management Solutions. The operators will quickly find their way around, and you benefit from well-maintained stock overviews, a neat and tidy storage. You maintain full circulation and storage transparency, and storing materials in the wrong place is a thing of the past – as well as machine downtimes due to missing tools or grinding wheels.

Optimally Managed – ZOLLER »keeper«

3

The ZOLLER »keeper« is the ideal solution to store and manage your complete tools, tool holders and grinding wheels used in your production process. Thanks to networking with TMS Tool Management Solutions, you can view the storage location of your tools and grinding wheels at all times.



»keeper«

Benefits for your storage management

- Convenient thanks to sturdy heavy-duty rollers
- Ergonomic handles
- Flexible tool frames



Technical Data	3 Pull-out drawers	5 Pull-out drawers
Cabinet size (H x W x D)	2000 x 1000 x 1050 mm	2000 x 1000 x 1050 mm
Drawer depth	810 mm	810 mm
Payload per vertical pull-out drawer	max. 1000 kg	max. 1000 kg
Tool frames per drawer	Standard 6	Standard 6
Design	Mechanical/electronic	Mechanical/electronic
Tool inserts SK, HSK, VDI, PSC	Size on request	Size on request
Tool inserts blank	B58/B75/B120	B58/B75/B120
Tool inserts adapter tool post	D 78 VSH size 1	D 78 VSH size 1
Tool inserts wooden	Blank/D 42	Blank/D 42



Find out more about the ZOLLER »keeper« on: solutions.zoller.info/en/smart-cabinets



Storage location management for unique identification of your tools

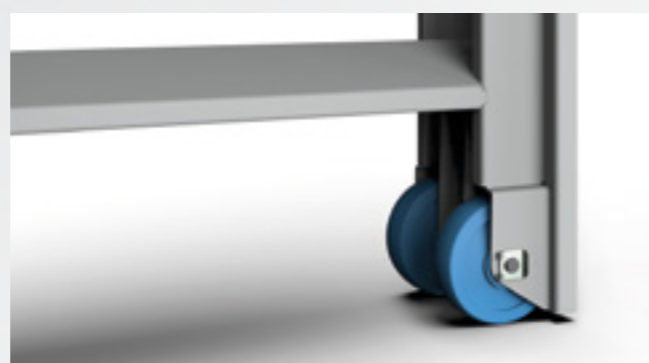

Sturdy heavy-duty rollers to move the drawers easily



Variety of tool inserts

The tool inserts are configured for space-saving storage of all common systems. For permanent marking of the storage locations of your tools and grinding wheels, the ZOLLER marking set offers the optimal solution. The marking is quickly visible with storage location in text form and as a DataMatrix code.

Precisely Balanced – ZOLLER »toolBalancer«

4

With the ZOLLER »toolBalancer«, you increase your process reliability and the quality of your components, reduce machine maintenance costs and prevent machine failures. With optimally and highly-precisely balanced tools, you achieve longer tool life, a longer spindle running time and a better surface quality of your components. With the »toolBalancer«, you get your tools into the perfect balance of sustainability, efficiency and progress.



»toolBalancer 550«

»toolBalancer 750«

Benefits for your balancing processes

- 100% made by ZOLLER
- 500 kg massive basis
- Best balancing results: < 0.4 gmm



Technical Data	»toolBalancer 550«	»toolBalancer 750«
Dimensions with integrated control unit (monitor holder) (H x W x D)	1044 x 1725 x 807 mm	1044 x 1960 x 807 mm
Dimensions with separate »cockpit« control unit (H x W x D)	1740 x 1725 x 1225 mm	1740 x 1960 x 1225 mm
Weight of standard version	740/730 kg	755/745 kg
Maximum tool diameter/maximum tool length	480 mm/550 mm	480 mm/750 mm
Maximum tool weight/maximum spindle speed	30 kg/1200 R/min	30 kg/1200 R/min
Measuring accuracy	< 0.4 gmm	< 0.4 gmm



Find out more about the ZOLLER »toolBalancer« on: solutions.zoller.info/en/toolbalancer



Device interior with interior lighting and practical storage areas



The ergonomic membrane keypad for safe measuring sequences



High-precision spindle

The selection of high-precision ZOLLER balancing adapters with a unique design facilitate power-activated and safe clamping of SK, HSK, polygonal shank coupling adapters and more, with even better repeat precision than ever before. In addition, accidents and damage caused by balancing adapters that are not screwed into the spindle are prevented.

Compactly Inspected – ZOLLER »smileCheck«

5

With the ZOLLER »smileCheck«, you ensure reliable processes and more speed in your production. The »smileCheck« is impressive not only because of its convenient operating concept, but because of its compact design. Tool parameters, geometry data and cutting contours can be recorded both radially and axially. The »smileCheck« also enables you to prepare your grinding wheel packs quickly and precisely.



»smileCheck«

Benefits for your tool inspection

- Functional design
- Universal for all tool holders
- Maximum operating comfort



Technical Data	»smileCheck«
Maximum tool length Z	420/600/800 mm
Maximum tool diameter D	420/460/620 mm
Maximum snap gauge diameter d	70 mm
Travel range Y-axis	± 50 mm
Number of axes	3-4

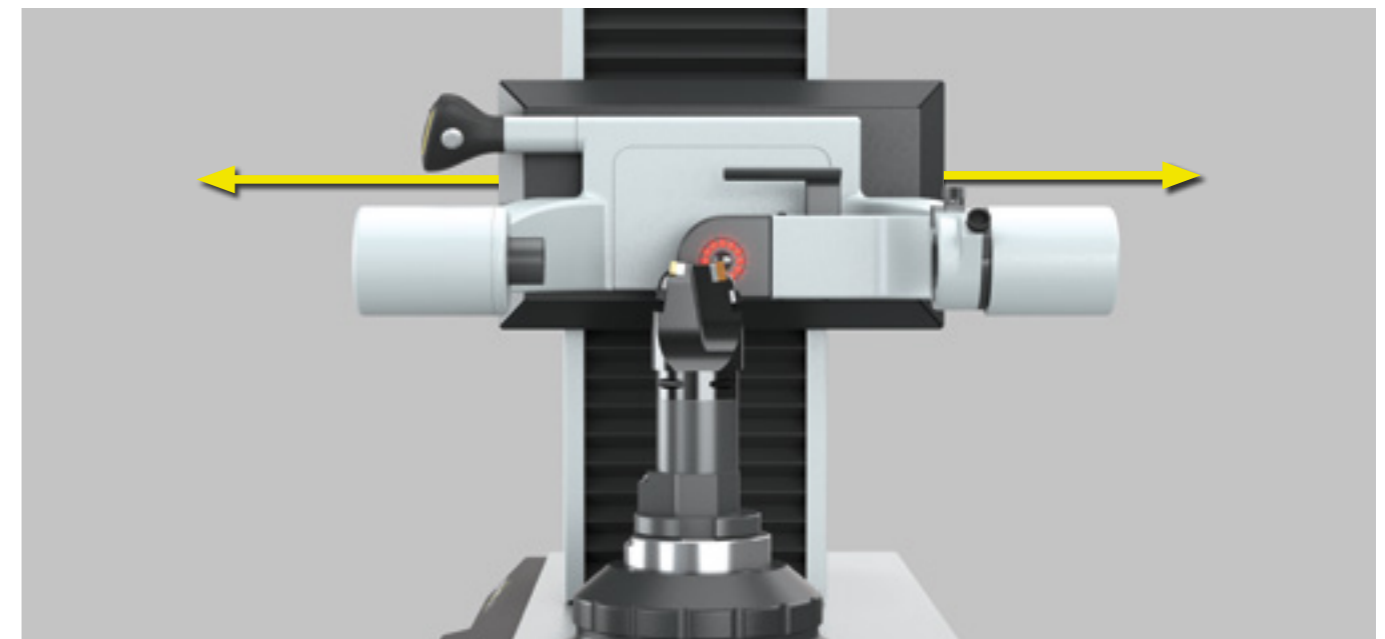

Find out more about the ZOLLER »smileCheck« on: solutions.zoller.info/en/smartcheck



High-precision spindle
SK 50



Vacuum tool clamping

High-precision spindle
»pcs«



Power-operated tool clamping



Manual fine adjustment as an alternative to CNC control

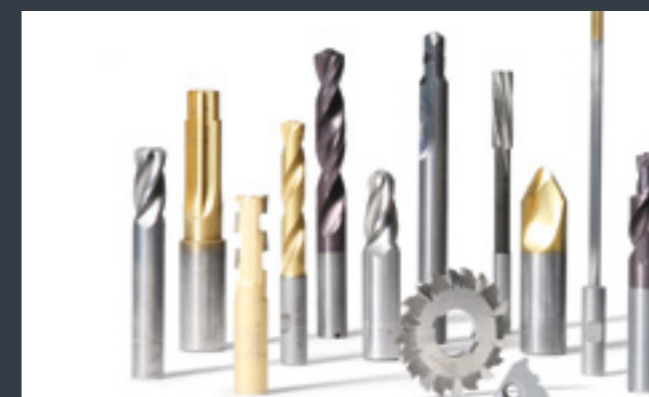

Software packages »inspection«

»Basic«, »Advanced«, »Premium« flexibly extend the range of functions of the basic version according to the respective measurement requirements. The data creation of the measuring programs is unsurpassed in its simplicity. The photo-realistic input dialog »fored« guides you safely through the parameter input.

Process-Oriented – ZOLLER »smartCheck«

5

With the ZOLLER »smartCheck«, you have everything you need for a comprehensive tool inspection: State-of-the-art technology paired with outstanding ease of use ensure efficient process sequences in your production. The wide variance of measuring ranges and the variable equipment make the »smartCheck« the perfect solution for your demanding range of tools. You can rely on precise measurement data that guarantees the quality of your products.



»smartCheck 450«

»smartCheck 600«

Benefits for your tool inspection

- Production at premium level
- Universal quality control
- Certified safety



Technical Data	»smartCheck 450«	»smartCheck 600«	»smartCheck 800«
Maximum tool length Z	450/620/820 mm	600/800/1000/1200 mm	600/800/1000/1200 mm
Maximum tool diameter D	420/460/620 mm	560/600/660/800 mm	860/1000 mm
Maximum snap gauge diameter d	70 mm	65/85 mm	85 mm
Travel range Y-axis	± 50 mm	± 100 mm	-
Number of axes	3-4	3-4	3-4



Find out more about the ZOLLER »smartCheck« on: solutions.zoller.info/en/smartcheck



High-precision spindle »ace« for µm-precise toolholding

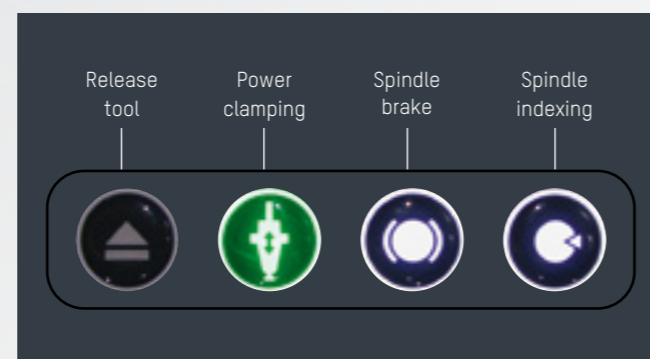

Simple operation of the dust-resistant membrane keypad



High-Precision Optics

Cutting edge radii, angles, lengths, diameters, etc. can be measured automatically and with µm-accuracy on the outer contour of the tools using transmitted light. Stored measurement sequences are carried out fully automatically at the touch of a button (CNC version). In incident light, manual measurements can be carried out in the chip space, on the circumference and on the face. The cutting edge detection supports operator-independent measurements.

Precisely Inspected – ZOLLER »genius«

5

With the ZOLLER »genius«, you are always guaranteed μm -accurate measurement results – even in the production environment. Its metrological precision is based on exact mechanics and highly accurate optics. The »pilot 4.0« operating software offers every user a high level of convenience with customized options. The ZOLLER »genius« is already used by more than 1800 enthusiastic customers worldwide – indispensable measuring technology that impresses.



»genius«

Benefits for your tool inspection

- Customer-oriented overall concept
- Comprehensive range of services
- Storage of measurement sequences in the z.One database



Technical Data	»genius«
Maximum tool length Z	600 mm
Maximum tool diameter D	400/260 mm
Maximum snap gauge diameter d	100 mm
Number of axes	5-6
Weight	~ 820 kg



Find out more about the ZOLLER »genius« on: solutions.zoller.info/en/genius



High-precision spindle »ace« with quick-change system



The »elephant 2.0« software is based on innovative AI technology



The »genius« universal measuring machine

Every cutting tool is a specialist. An expert should measure it precisely and verify its quality. With the ZOLLER »genius«, you can measure over 100 parameters of your precision tools in 2D/3D without contact, fully automatically and impressively reliably. Every measured value provides you with the basis for improving the quality of your products.

Universally Measured – ZOLLER »threadCheck | cc«

5

With the ZOLLER »threadCheck | cc«, you are offered a universal genius: Intelligent multi-sensor technology and the functional full enclosure, in combination with the universal toolholding system including tailstock, make the ZOLLER »threadCheck | cc« unique worldwide. Equipped with a CNC-controlled swiveling optics carrier and transmitted light and incident light image processing, you can precisely and automatically measure almost anything on cutting tools of any kind as well as on threading and gear cutting tools.



»threadCheck | cc«

Benefits for your tool inspection

- Universal multi-sensor and clamping technology
- Comprehensive performance range
- Innovative high-end design



Technical Data	»threadCheck cc«
Maximum tool length Z	600 mm
Maximum tool diameter D	420 mm
Maximum snap gauge diameter d	100 mm
Travel range Y-axis	± 50 mm
Number of axes	6–7
Weight	~ 1260 kg



Find out more about the ZOLLER »threadCheck | cc« on: solutions.zoller.info/en/threadcheckcc

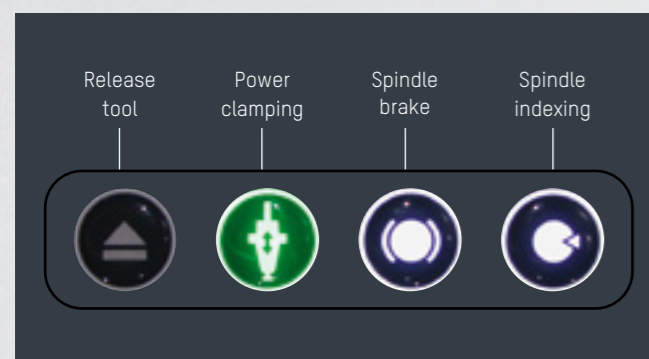

Simple operation of the dust-resistant membrane keypad

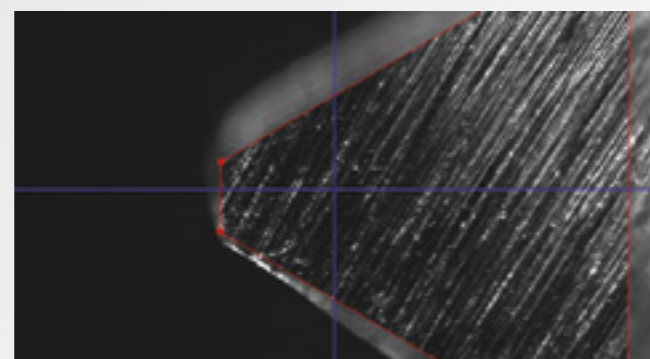

3D contour measurement in the chip space



Functionality at the highest level

In every new development, factors such as ergonomics, operation and comfort at the workplace play a decisive and competitive role. The »threadCheck | cc« ensures ideal accessibility and allows a highly precise measuring process. Other highlights include the flexibility of the »cockpit« and accessory shelves as well as the innovative multi-sensor system – all aspects to ensure functionality and productivity at the highest level.

Automatically Inspected – ZOLLER »titan«

5

With the ZOLLER »titan«, simple, fast and profitable production processes are possible. Even highly complex measurements can be carried out fully automatically, independently of the operator and with an inspection report at the touch of a button. From random sample measurements to complete inspections, the »titan« measures fully automatically and with μm -accuracy. The centered multi-LED ring lights ensure ideal illumination on every tool for inspections on the face, on the circumference and in the chip space. In addition, the »zep« measuring sensor measures the cutting edge preparation without contact.



»titan«

Benefits for your tool inspection

- State-of-the-art technology
- High-precise high-end measuring machine
- Maximum operating comfort



Technical Data	»titan«
Maximum tool length Z	600 mm
Maximum tool diameter D	230/100 mm
Maximum snap gauge diameter d	100/75 mm
Number of axes	5-7
Weight	~ 1400 kg



Find out more about the ZOLLER »titan« on: solutions.zoller.info/en/titan



High-precision spindle
»tcs«



Power-operated tool clamping

High-precision spindle
»ahd«



Automatic hydraulic clamping



Centered multi-LED ring lights ensure ideal illumination

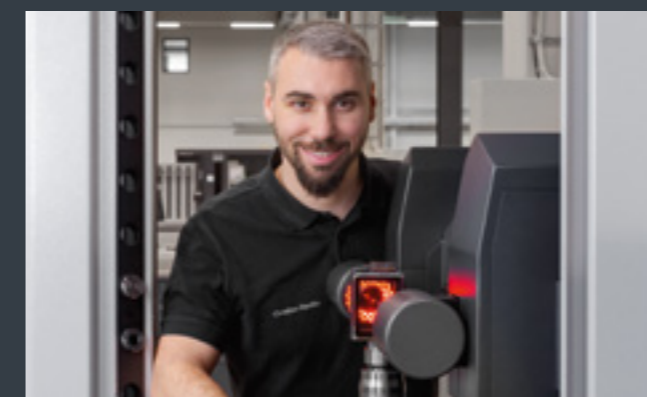

Every »titan« is a promise

A tool measuring machine only becomes outstanding when its precision is available to everyone. The ZOLLER »titan« achieves the best results thanks to high-end components, a unique axis concept and decoupled measuring technology, as well as powerful software, extensive automatic functions and clever ergonomic elements. The »cockpit« control unit, for example, can be individually adjusted to the operator's needs for user-friendly and comfortable working.

Tooth By Tooth Inspected – ZOLLER »hobCheck«

5

With the ZOLLER »hobCheck«, the quantum leap for your production, you are perfectly equipped for inspection tasks through to fully automatic complete inspection of all types of gear cutting tools. Benefit from higher quality of tools, shorter set-up times on machines, less stock removal during sharpening and complete documentation.



»hobCheck«

Benefits for your tool inspection

- Fully automatic measuring technology
- Comprehensive complete measurement
- Production at premium level



Technical Data	»hobCheck«
Maximum tool length Z	600/800/1000 mm
Maximum tool diameter D	420 mm
Maximum snap gauge diameter d	100 mm
Travel range Y-axis	± 40 mm
Weight	~ 542/557/572 kg



Find out more about the ZOLLER »hobCheck« on: solutions.zoller.info/en/hobcheck



High-precision spindle »ace« with power-operated tool clamping

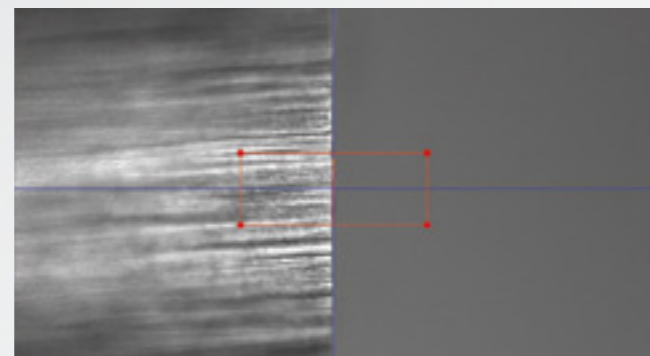

Incident light focus/2D incident light measurement on circumference



High-precision sensors for gear cutting tools

With the ZOLLER »hobCheck«, you can complete tactile measuring without contact in transmitted light and incident light. Equipped with a CNC-controlled swiveling optics carrier, electronic measuring probe and transmitted light and incident light image processing, parameters such as tooth profile, concentricity/wobble, pitch and many more can be measured automatically on hob cutters in accordance with DIN 3968. The ZOLLER »pilot 4.0« software takes care of all calculations, positioning processes and the assignment of sensors to the respective measuring task.

Without Contact Inspected – ZOLLER »pomBasicCompact«

7

With the ZOLLER »pomBasicCompact«, you have a specialist for inspecting and measuring machining shank tools at your side. The measuring technology is based on contact-free measurements of the tools. The »pomBasicCompact« consists of a digital zoom lens. All axes can be adjusted using manual fine settings.



»pomBasicCompact«

Benefits for your tool inspection

- Highly precise inspection and measuring technology
- Compact overall concept
- Maximum operating comfort



Technical Data	»pomBasicCompact«
Travel range X-axis	45 mm
Travel range Y-axis	170 mm
Travel range Z-axis (camera)	45 mm
Clampable and measurable diameter	3 mm to 40 mm
Lens	Macro lens with digital zoom, high-definition, monochrome, field of view 18 x 12 mm, resolution 20 Mpx
Working distance	90 mm



Find out more about the ZOLLER »pomBasicCompact« on: solutions.zoller.info/en/pombasic

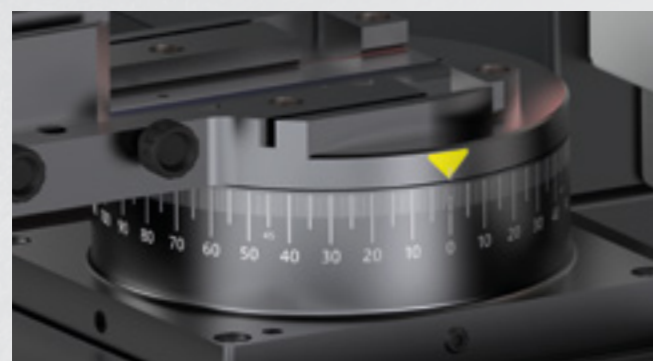

Swivel table ensures safety for exact measurement results



Additional lighting with LED spot

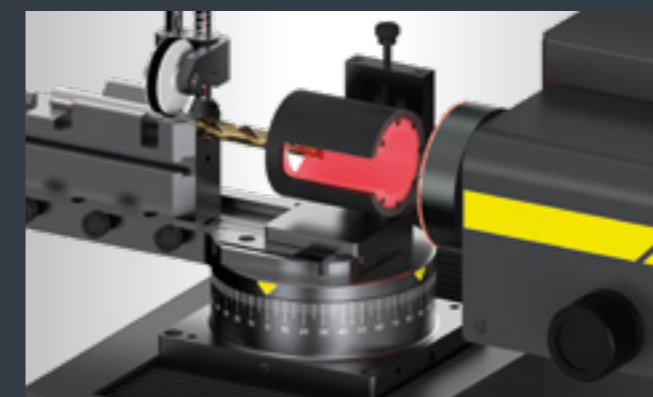

ZOLLER »pomLightTube« illumination unit

The additional illumination »pomLightTube« ensures consistent, optimal and high-contrast lighting of the tools for radial and axial incident light measurements.

Inspected with »pomBasic« and »pomBasicMicro«

7

With the ZOLLER »pomBasic« & »pomBasicMicro«, you save yourself unnecessary trips to the measuring room and benefit from efficient processes and precise results in record time. The »pomBasic« and »pomBasicMicro« inspection units impress with reliable measuring. Insert the tool, align it, check it and you're done. This is how you can inspect almost all shank tools easily and reliably. Automatic edge detection guarantees fast measurement with high accuracy.



»pomBasic«

Benefits for your tool inspection

- Compact inspection and measuring technology
- Convenient operator guidance
- Innovative axis principle



Technical Data	»pomBasic«	»pomBasicMicro«
Travel range X-axis	180 mm	180 mm
Travel range Y-axis	55 mm	55 mm
Travel range Z-axis (camera)	± 50 mm	± 50 mm
Clampable shaft diameter	0.5 mm to 50 mm (depending on tool holder)	0.5 mm to 50 mm (depending on tool holder)
Zoom lens	Video microscope system color with 6.5x optical zoom	Video microscope system monochrome with 12x optical zoom
Working distance	90 mm	50 mm

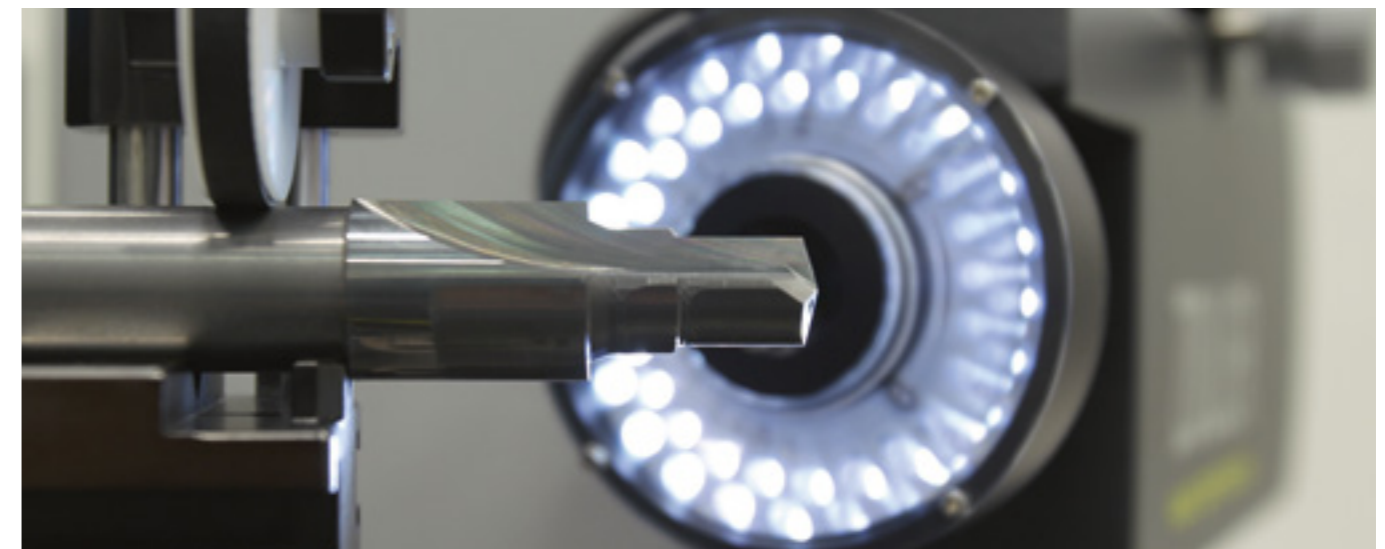

Find out more about the ZOLLER »pomBasic« & »pomBasicMicro« on: solutions.zoller.info/en/pombasic



The big stage for micro tools

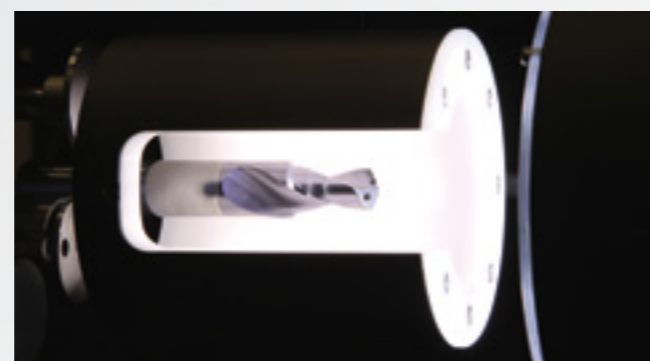

Optimum lighting of complex geometries with »pomLightTube«

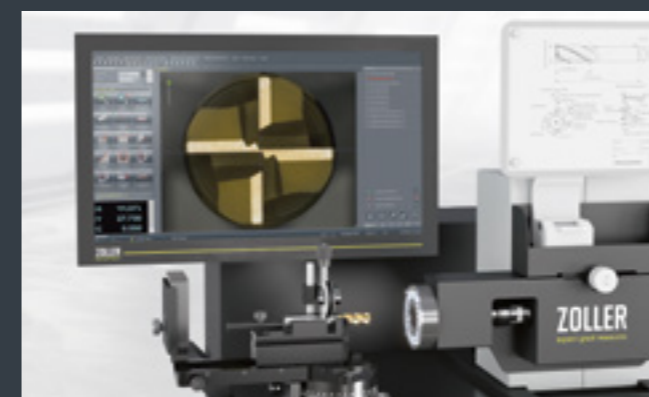

Automatic inspection with the macro function

Do you have repetitive measuring tasks and want to carry them out effectively? ZOLLER has the perfect solution. Thanks to the macro function, repeat measurements can be saved easily and reliably. A reference image serves as a template. As soon as the tool is positioned congruently with the template, a single press of a button is all it takes to start the automatic measuring process, regardless of the operator. We call this intelligent ZOLLER comfort.

µm-Precisely Inspected – ZOLLER »µFocus«

7

With the ZOLLER »µFocus«, you use non-contact measurement procedures to determine the surface roughness and cutting edge preparation of your tool, down to the µm. Use the ZOLLER »µFocus« to create fully optimized tools: You will produce the perfect cutting edge – one that ensures a long tool life, minimal wear, optimal chip formation, and precision workpiece processing, thereby significantly lowering costs for production.

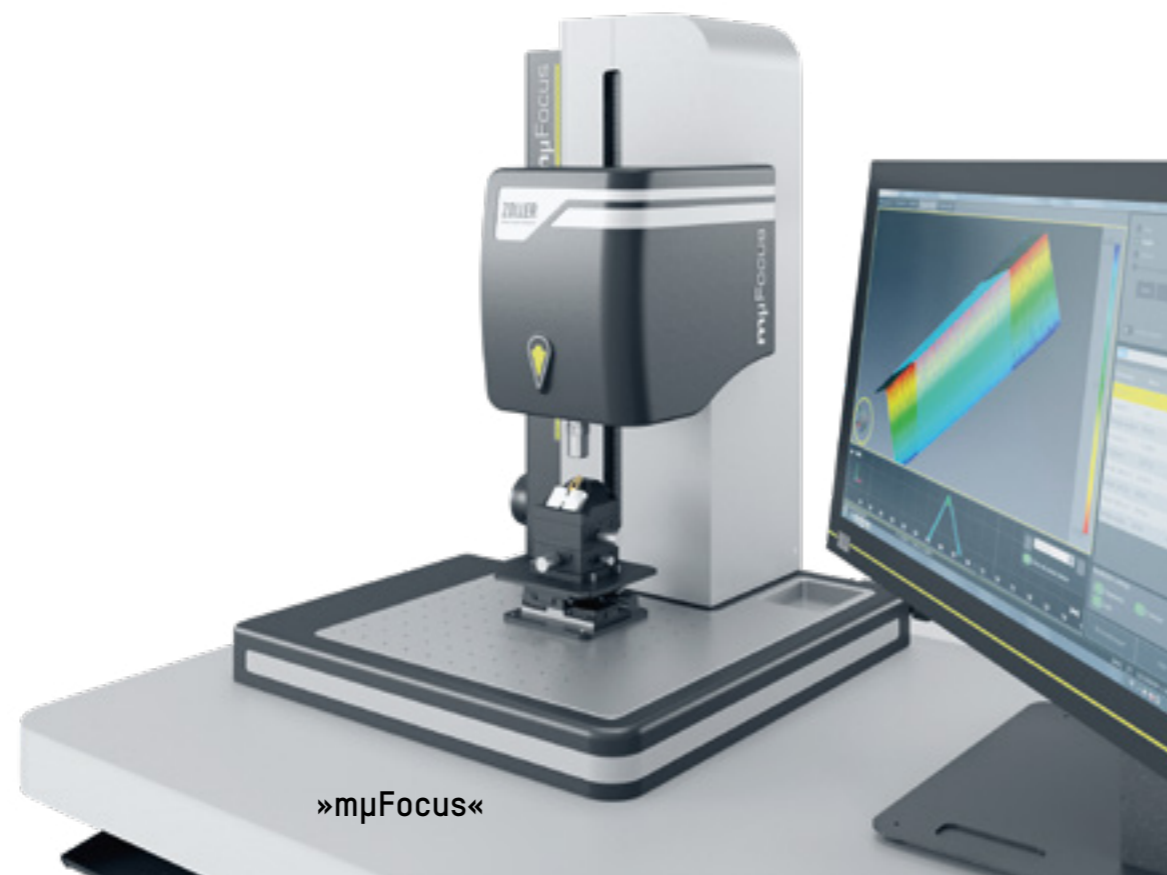

Benefits for your tool inspection

- Highest measuring accuracy of up to 0.1 µm
- The latest measurement technology software
- Ergonomic operation that meets workshop needs



Technical Data	»µFocus« with »zep« sensor	»µFocus« with »zep-R« sensor
Z-axis	300 mm	300 mm
Working distance	30 mm	20 mm
Measuring principle	Stripe projection	Confocal microscope
Smallest measurable radius	3 µm	3 µm
Numeric aperture	-	0.42



Find out more about the ZOLLER »µFocus« on: solutions.zoller.info/en/inspection-measuring/mufocus

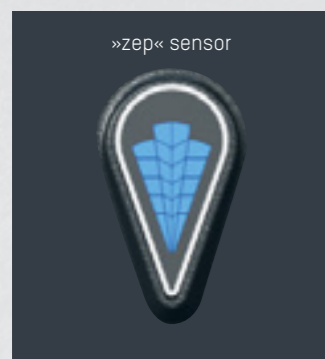

For the cutting edge preparation

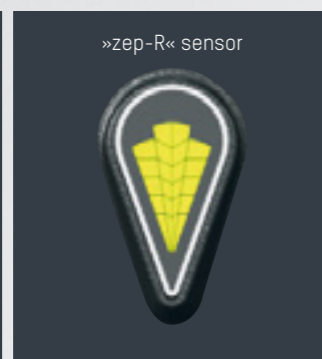

To analyze surface roughness



Securely clamp your tools and bring them into position

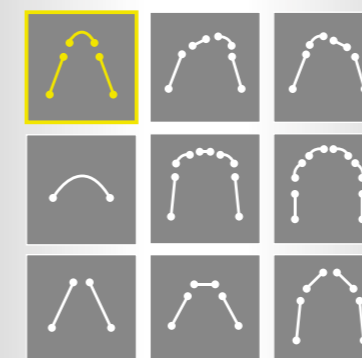

Ready for different geometry types

You always have a choice, including different analysis options. »µFocus« can handle almost any kind of analysis, and shows a graphic display of shapes. Just click, start the analysis, and display your results. With »µFocus«, you gain an easy advantage in developing tool innovations. Large, clear symbols make it easy to make your selection. The cutting edge form Vec-Arc-Vec (line, arc, line) was identified in the example.

Automatically Measured – ZOLLER »roboSet 2«

8

With the ZOLLER »roboSet 2«, you automate your »genius«. After loading the pallets with tools, the automatic intermediate sleeve change starts. In the »roboClean« upstream tool cleaning, the tools are cleaned in an ultrasonic bath before they are clamped and measured in the »genius«. All measurements are fully documented. After the measurement, the »roboMark« laser marks the shank of the tool within milliseconds with values and other data individually determined during the measuring process.

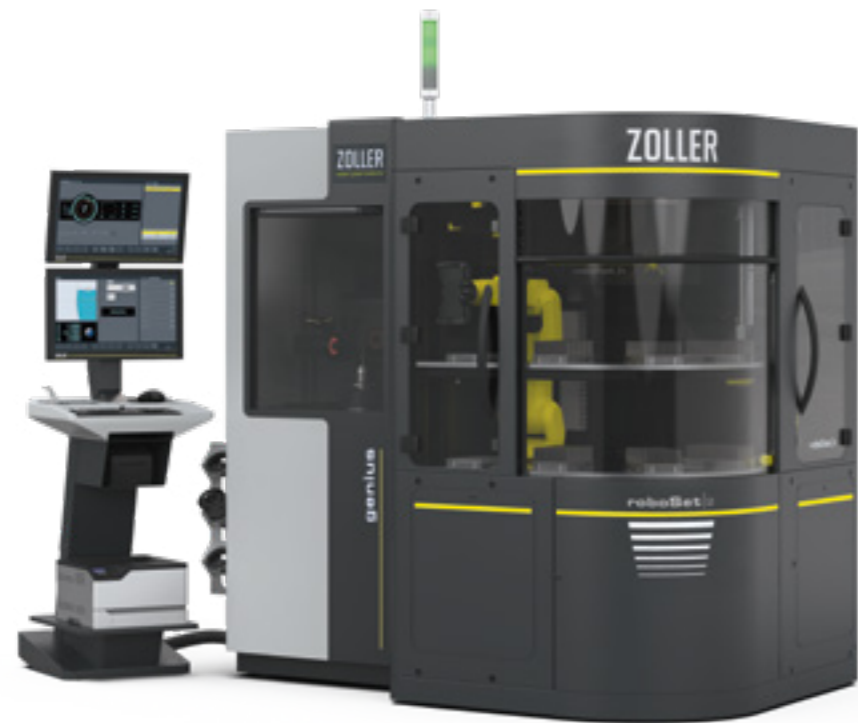

»roboSet 2«

Benefits for your tool inspection

- Automatic measurement and inspection, 24/7
- High loading capacity
- Flexible pallet management system



Technical Data	»roboSet 2«
Range	920 mm
Positioning accuracy	±0.03 mm
Maximum load capacity	7 kg without gripper
Working area	1050 x 350 mm
Number of pallets	8



Find out more about the ZOLLER »roboSet 2« on: solutions.zoller.info/en/automation/roboset-2



Automatic and contactless Weldon detection



Cleaning of the tool cutting edges in the ultrasonic bath

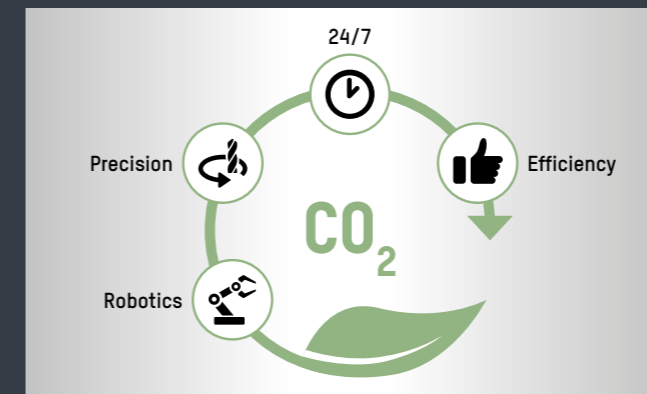

This is how sustainability works

With the »roboSet 2«, you manufacture in a climate-conscious way and maximize the overall efficiency of your processes. Let modular robot precision work for you: Automated technology – state-of-the-art, flexible, 24/7.



Your Customer Portal
www.myzoller.com

simple. direct. online.

ZOLLER Solutions

More speed, higher quality, safe processes – with ZOLLER, you increase the efficiency of your production. ZOLLER offers you outstandingly precise devices for adjusting, measuring and testing cutting tools, software, interfaces, cloud services and solutions for the automation of tool processes. You can combine all of this to create your individual system solution – on your way to the smart factory.

Presetting & Measuring

Tool Management

Inspection & Measuring

Automation

Everything from a Single Source.
Everything for your Success.
Everything with ZOLLER Solutions.

ZOLLER
expect great measures

ZOLLER UK

Faraday House, Woodyard Lane,
Foston, Derby DE65 5BU

T: 01283 499566
www.zoller-uk.com